

MENUMASTER[®] Commercial

Project #: _____

Item #: _____

AIA File #:

Specification #:



Model RFS518TS shown

Medium Volume

Menumaster Commercial Microwave Model RFS518TS

Power Output

- 1800 watts of power.
- Five power levels for consistent, delicious results for frozen, refrigerated and fresh foods - from the freezer to table in minutes.

Easy to Use

- Up to 100 programmable menu items simplifies cooking and ensures consistent results.
- Four stage cooking option for easy one-touch cooking.
- Multiple quantity pad calculates the proper cooking times for multiple portions.
- User friendly touch controls are easy to use.
- Time entry option for added flexibility.
- Digital display with countdown timer for simple operation and "at-a-glance" monitoring.
- Braille touch pads.
- See-through door and lighted interior for monitoring without opening the door.
- 34 Liter (1.2 cubic ft.) capacity accommodates a 356 mm (14") platter, prepackaged foods and single servings.
- Stackable to save valuable counter space.

Easy to Maintain

- Stainless steel exterior and interior for easy cleaning and a professional look.
- Removable air filter protects oven components.
- Constructed to withstand the foodservice environment.
- ETL Listed.

Medium Volume

This category of microwave is ideal for...

Applications:

- Pizza restaurants
- Casual dining
- Clubs
- Deli

Defrost:

- Defrosts most frozen food products

All ACP, Inc. commercial ovens are backed by our Culinary Center. Call us with any question regarding food preparation, menu development and cooking times. 866-426-2621.



MenuMaster Commercial Microwave Model RFS518TS | Medium Volume

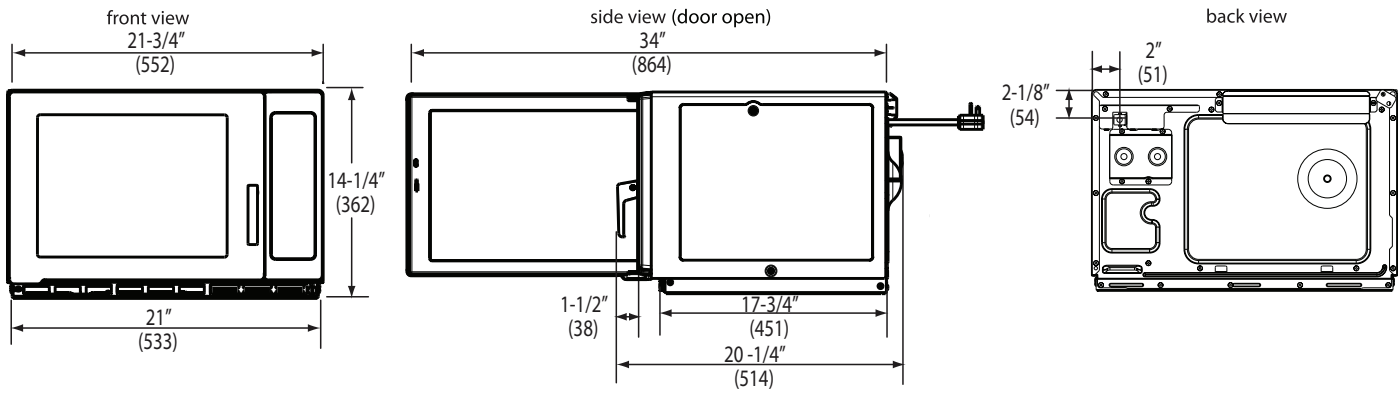

Installation clearance: 2" sides & 12" top

Specification #:

| Specifications | | | |
|---------------------------|----------------------------------|-----------------------|------------------|
| Model | RFS518TS | UPC Code 728028043181 | |
| Configuration | Countertop | | |
| Control System | Touch | | |
| Programmable Control | 10 pads | | |
| Settings Programmable | 100 | | |
| Max. Cooking Time | 60:00 | | |
| Power Levels | 5 | | |
| Defrost | Yes | | |
| Time Entry Option | Yes | | |
| Microwave Distribution | Rotating antennas, top & bottom | | |
| Magnetron(s) | 2 | | |
| Display | LED | | |
| Stackable | Yes | | |
| Stage Cooking | Yes, 4 | | |
| Interior Light | Yes | | |
| Door Handle | Pull Handle | | |
| Signal | End of cycle, adjustable | | |
| Air Filter | Removable with cleaning reminder | | |
| Multiple Portion Setting | Yes, X2 | | |
| Exterior Dimensions | H 362 (14 1/4") | W 552 (21 3/4") | D*514 (20 1/4") |
| Cavity Dimensions | H 226 (9") | W 362 (14 1/4") | D 416 (16 3/8") |
| Door Depth | 864 (34"), 90°+ door open | | |
| Usable Cavity Space | 34 Liters (1.2 cubic ft.) | | |
| Exterior Finish | Stainless steel | | |
| Interior Finish | Stainless steel | | |
| Power Consumption | 2700 W, 12 A | | |
| Power Output** | 1800 W** Microwave | | |
| Power Source | 230V, 50 Hz, 16 A single phase | | |
| Plug Configuration / Cord | CEE 7/7 "Schuko" | 1.5 m (5 ft.) | |
| Frequency | 2450 MHz | | |
| Product Weight | 29 kg. (64 lbs.) | | |
| Ship weight (approx.) | 32 kg. (71 lbs.) | | |
| Shipping Carton Size | H 583 (22 5/16") | W 654 (25 3/4") | D 456 (17 5/16") |

Specifications

Commercial microwave 10 touch pad control panel shall be programmable with the ability to program up to 100 menu items with two multiple portions. Touch pad shall include Braille for ADA compliance. Cooking timer shall be 60 minute, countdown style with a time entry option and an adjustable end of cycle audible signal. LED display shall be a backlit. There shall be 5 power levels, including defrost and 4 cooking stages. Microwave output shall be 1800 watts distributed by two magnetrons with rotating top and bottom antennas to provide superior even heating throughout the cavity. Durable door shall have a tempered glass window and a grab and go handle with a 90°+ opening for easy access. An interior light shall facilitate monitoring without opening the door. The large 34 Liter (1.2 cubic ft.) cavity shall accommodate a 356 mm (14") platter. Interior ceramic shelf shall be sealed and recessed on oven bottom to reduce plate-to-shelf edge impact. Oven shall have a stainless steel interior and exterior and be stackable to save counter and shelf space. Front air filter shall be removable and have a clean filter reminder. Microwave oven shall comply with standards set by the U.S Department of Health and Human Services, ETL listed.



Intertek



Warranty

Warranty Certificate for this product can be found by locating it on the ACP, Inc. website at:

www.acpsolutions.com/warranty



AIA File #:

Measurements are in millimeters

* Includes handle

** IEC 60705 Tested

